

MDM-5000 DIRECT DRIVE SETS

PRODUCT GUIDELINES

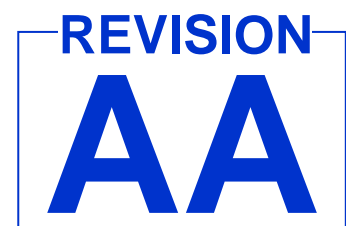

This documentation may not be copied, photocopied, reproduced, translated, or reduced to any electronic medium or machine-readable format without explicit written permission from CLEVELAND MOTION CONTROLS.

Copyright © 2007
Cleveland Motion Controls, Inc.
7550 Hub Parkway
Cleveland, Ohio 44125-5794
Tele: 216.524.8800
Fax: 216.642.2199

INTRODUCTION

MDM-5000 Direct Drive Sets have been designed to fit into applications where size and weight are important considerations. They are supplied as two pieces; a cut-core segmented stator and a rotor. The stator is molded in a thin walled aluminum housing using thermally conductive epoxy, which provides excellent heat transfer and protects the windings (and optional integrated Hall board) from damage during installation and handling. The rotor is coated with a polymer shrink wrap which protects the magnets from dislodging during operation and also prevents damage while handling.



FEATURES & BENEFITS

- High performance Brushless design provides zero maintenance
- MDM 5000 technology
 - Cut-core or Segmented Stator Technology
 - High slot-fill winding for high efficiency
 - Stator molded in thin wall aluminum housing using thermally conductive epoxy
 - Excellent heat transfer
 - High torque density
 - Winding and Hall Board (when used) protected from handling damage
 - Rotor protected with polymer shrink wrap
 - Protects magnets from dislodging during operation
 - Handling damage avoided
- High pole count for Low Cogging and Smooth Operation
- High torque to inertia ratio ideal for high acceleration/deceleration mode with rapid start-stop
- Low electrical time constant for Fast Response
- Minimize size & weight simplifies installation
- Maximize rate & position accuracy Direct drive
 - No belts, no gearing, no backlash
 - High servo stiffness

ORDERING INFORMATION

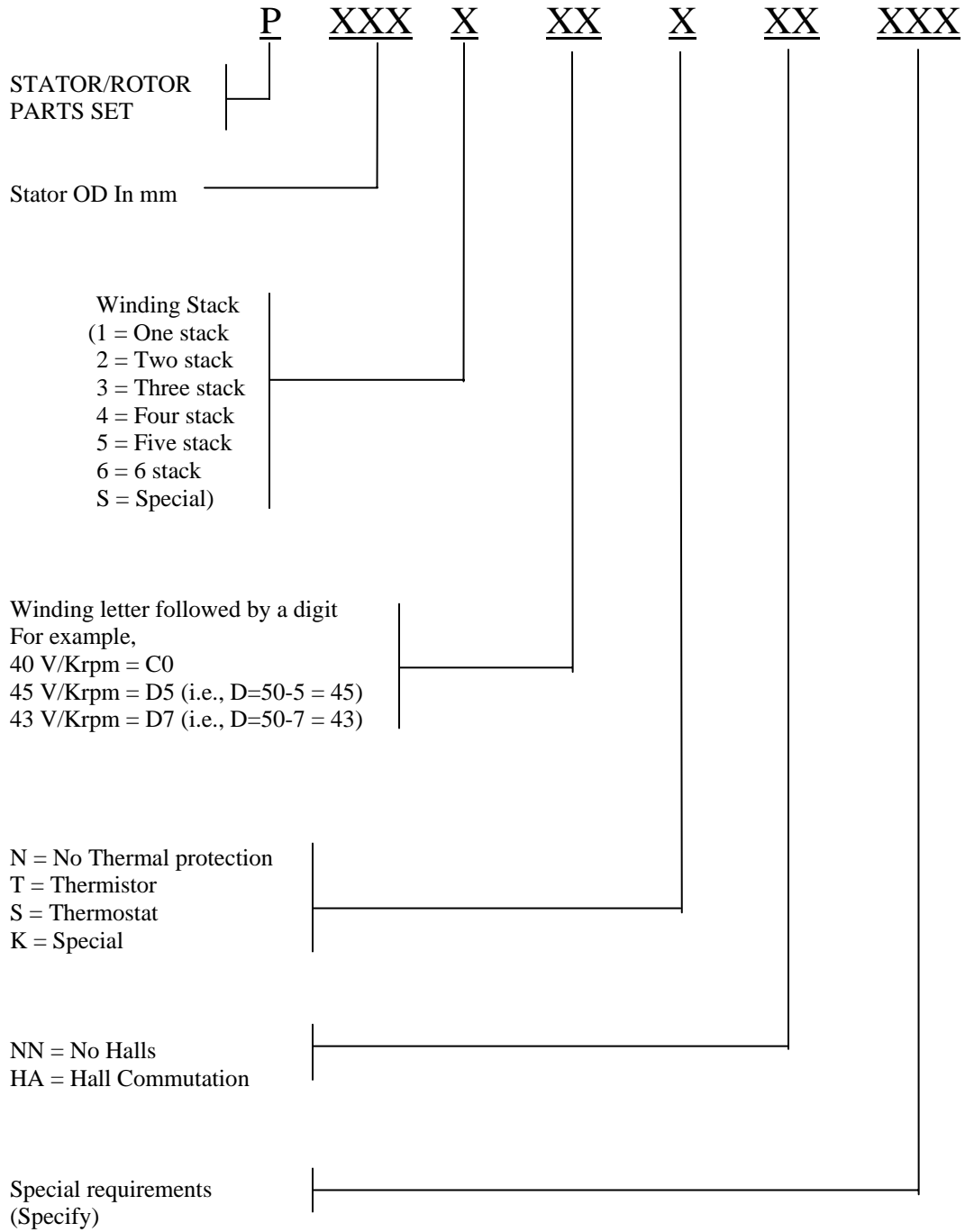

SAFETY



Rare-Earth magnetic products should be handled with care. These magnets are very powerful and can accelerate at great speeds toward each other and toward ferrous material. When these magnets come together quickly, they can shatter and break sending particles at high speed. These magnets can also pinch strongly if allowed to come together against the skin. You should always wear gloves and eye protection when handling these strong magnets.

The strong magnetic fields of these magnets can damage magnetic media such as floppy disks, credit cards, magnetic I.D. cards, cassette tapes, video tapes or other such devices. They can also damage televisions, VCRs, computer monitors and other CRT displays. Never place neodymium magnets near electronic devices.

CAUTION!

Never allow these magnets near a person with a pacemaker or similar medical aid. The strong magnetic fields of the magnet can affect the operation of such devices.

PACKAGING

The various components are packaged in bubble wrap to assure that they remain separated during shipment. This also prevents damage during shipment.

UNPACKING

In preparation for assembly, remove all components from the bubble wrap and be very careful to avoid damaging the components. Improper handling may substantially degrade motor performance.

The rotor is manufactured using very powerful and fragile Rare-Earth magnets. Do not place rotors close to another rotor, stator or near other ferromagnetic materials. The attractive forces of Rare-Earth magnets may cause damage to the components and/or bodily harm.

COMPONENT MOUNTING

GENERAL

The Direct Drive Set consists of a stator and a rotor. The stator may have a fully adjusted integrated commutation PCB assembly depending on the customer need. All stators are molded with thermally conductive epoxy for additional heat dissipation which also protects the stator winding and the commutation PCB assembly (when supplied) from physical damage.

STATOR

The recommended installation procedure is to bond the stator to the housing using:

Loctite # 332 with activator # 7387/7380
(or, Loctite #325 and activator # 7075)

...or equivalent. Follow adhesive manufacturer's recommendations during bonding procedure.

A shoulder should be provided in the housing for a positive stop and consistency in the assembly procedure. It is also important to radially align the stator with the rotor for best performance. Since the stator is molded with thermally conductive insulating material, there is no danger of grounding the stator to the housing.

The inside diameter of the housing should be 0.03 to 0.05 mm larger than the outside diameter of the stator. A large clearance between the inside diameter of the housing and outside diameter of the stator will result in an eccentric air gap, which will increase cogging torque, reduce motor performance and increase probability of failure due to the rotor striking the stator.

ROTOR

The most common installation method is to permanently bond the rotor to the shaft using:

Loctite # 332 with activator # 7387/7380
(or Loctite #325 and activator # 7075)

...or equivalent. Follow the adhesive manufacturer's instructions.

A shoulder on the shaft or the use of retaining ring(s) (Waldes Tru-Arc or equivalent) is recommended to establish a positive location for the rotor. Additionally, keying or other means may also be used to act as an anti-rotational device.

When bonding the rotor, the shaft diameter tolerance should be held to 0.03 to 0.05 mm below the minimum rotor diameter. A large clearance between the rotor and the shaft will result in an eccentric air gap, which will increase cogging torque, reduce motor performance and increase the probability of failure due to the rotor striking the stator.

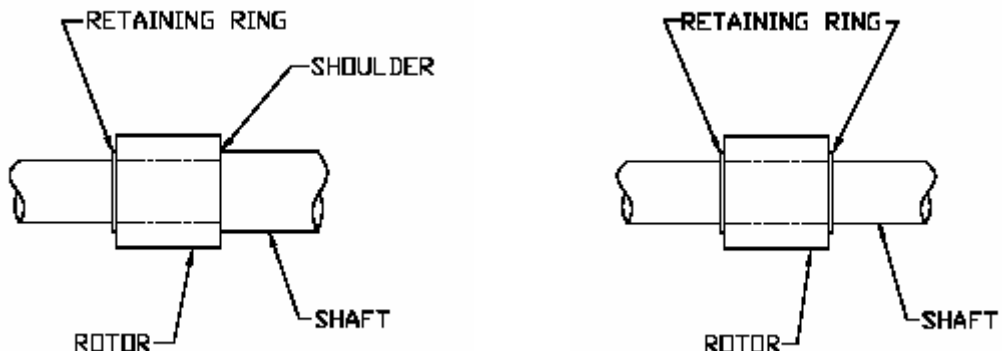

PRODUCT DIMENSIONS

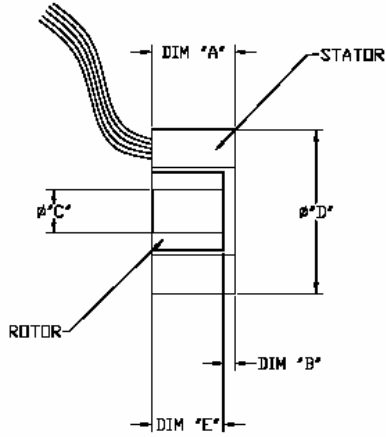

- A: Width of the stator
- B: Axial location of rotor with respect to the stator end opposite the leads
- C: Rotor inside diameter
- D: Stator outside diameter
- E: Width of rotor

Note:
All dimensions below are in millimeters (mm)

| Frame Size | With or Without Hall | | Cmax | D | E |
|------------|----------------------|---|-----------------|-----------------|------|
| | A | B | | | |
| P0551 | 39 | 6 | 16.00 +/- 0.038 | 55.00 +/- 0.038 | 21 |
| P0552 | 58 | 6 | 16.00 +/- 0.038 | 55.00 +/- 0.038 | 40 |
| P0553 | 77 | 6 | 16.00 +/- 0.038 | 55.00 +/- 0.038 | 60 |
| P0554 | 96 | 6 | 16.00 +/- 0.038 | 55.00 +/- 0.038 | 81 |
| | | | | | |
| P0631 | 30 | 4 | 28.95 +/- 0.038 | 60.35 +/- 0.038 | 15 |
| P0632 | 43 | 4 | 28.95 +/- 0.038 | 60.35 +/- 0.038 | 28 |
| P0633 | 56 | 4 | 28.95 +/- 0.038 | 60.35 +/- 0.038 | 42 |
| P0634 | 69 | 4 | 28.95 +/- 0.038 | 60.35 +/- 0.038 | 55 |
| | | | | | |
| P0651 | 33 | 4 | 18.00 +/- 0.038 | 65.00 +/- 0.038 | 20.3 |
| P0652 | 43 | 4 | 18.00 +/- 0.038 | 65.00 +/- 0.038 | 29.5 |
| P0653 | 59 | 4 | 18.00 +/- 0.038 | 65.00 +/- 0.038 | 49.3 |
| P0654 | 69 | 4 | 18.00 +/- 0.038 | 65.00 +/- 0.038 | 58.5 |
| | | | | | |
| P0761 | 34 | 5 | 23.00 +/- 0.038 | 75.95 +/- 0.038 | 20 |
| P0762 | 50 | 5 | 23.00 +/- 0.038 | 75.95 +/- 0.038 | 36 |
| P0763 | 65 | 5 | 23.00 +/- 0.038 | 75.95 +/- 0.038 | 55 |
| P0764 | 82 | 5 | 23.00 +/- 0.038 | 75.95 +/- 0.038 | 71 |

| Frame Size | | | Cmax | D | E |
|------------|-----|----|-----------------|------------------|-----|
| | A | B | | | |
| P0811 | 38 | 6 | 32.00 +/- 0.038 | 81.28 +/- 0.038 | 20 |
| P0812 | 55 | 6 | 32.00 +/- 0.038 | 81.28 +/- 0.038 | 37 |
| P0813 | 72 | 6 | 32.00 +/- 0.038 | 81.28 +/- 0.038 | 58 |
| P0814 | 89 | 6 | 32.00 +/- 0.038 | 81.28 +/- 0.038 | 73 |
| | | | | | |
| P1051 | 61 | 10 | 31.75 +/- 0.038 | 105.00 +/- 0.075 | 32 |
| P1052 | 92 | 10 | 31.75 +/- 0.038 | 105.00 +/- 0.075 | 63 |
| P1053 | 123 | 10 | 31.75 +/- 0.038 | 105.00 +/- 0.075 | 95 |
| P1054 | 154 | 10 | 31.75 +/- 0.038 | 105.00 +/- 0.075 | 126 |
| | | | | | |
| P1271 | 32 | 7 | 63.50 +/- 0.05 | 127.00 +/- 0.075 | 13 |
| P1272 | 42 | 7 | 63.50 +/- 0.05 | 127.00 +/- 0.075 | 23 |
| P1273 | 52 | 7 | 63.50 +/- 0.05 | 127.00 +/- 0.075 | 33 |
| P1274 | 62 | 7 | 63.50 +/- 0.05 | 127.00 +/- 0.075 | 45 |
| P1275 | 72 | 7 | 63.50 +/- 0.05 | 127.00 +/- 0.075 | 55 |
| P1276 | 82 | 7 | 63.50 +/- 0.05 | 127.00 +/- 0.075 | 65 |
| | | | | | |
| P1431 | 55 | 10 | 38.05 +/- 0.05 | 143.00 +/- 0.075 | 26 |
| P1432 | 80 | 10 | 38.05 +/- 0.05 | 143.00 +/- 0.075 | 51 |
| P1433 | 105 | 10 | 38.05 +/- 0.05 | 143.00 +/- 0.075 | 76 |
| P1434 | 130 | 10 | 38.05 +/- 0.05 | 143.00 +/- 0.075 | 101 |
| P1435 | 155 | 10 | 38.05 +/- 0.05 | 143.00 +/- 0.075 | 126 |

It is imperative that the axial location of the rotor is maintained within +/- 0.762 mm per the above dimension to ensure the highest performance of the Direct Drive Set.

ASSEMBLY PRECAUTIONS

When assembling the rotor into the stator, high radial and axial forces will be experienced. Proper precautions should be exercised during assembly to avoid damage to the rotor. Although the rotor is protected with polymer shrink-wrap additional precaution may be required to avoid damage.

IMPORTANT NOTE:

Always use certified outline drawings for best performance and trouble free assembly.

SIGNAL TIMING

A Commutation PCB Assembly, when required, is fully preset at the factory. No additional adjustments are required.

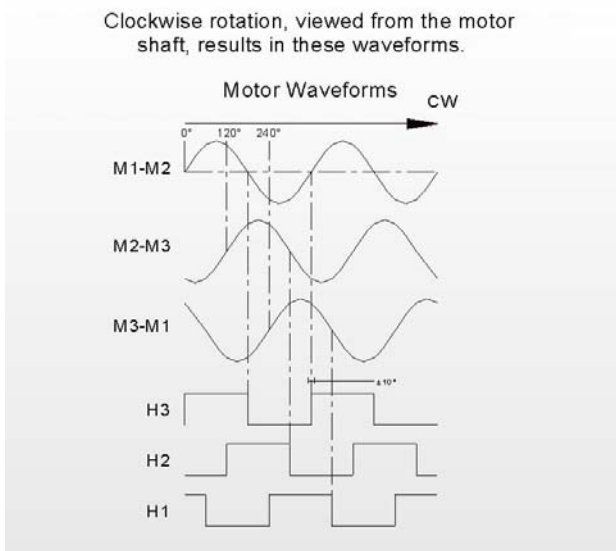

| MOTOR WIRING CODE | | |
|-------------------|------------|-----------|
| FROM | WIRE COLOR | WIRE SIZE |
| MOTOR M1 | WHITE | 18 AWG. |
| MOTOR M2 | BLACK | 18 AWG. |
| MOTOR M3 | RED | 18 AWG. |

| HALLS WIRING CODE | | |
|-------------------|------------|-----------|
| FROM | WIRE COLOR | WIRE SIZE |
| + 5 VDC | RED | 26 AWG. |
| COMMON | BLACK | 26 AWG. |
| H1 | ORANGE | 26 AWG. |
| H2 | YELLOW | 26 AWG. |
| H3 | GREEN | 26 AWG. |

BEARINGS

The bearing type and size shall be selected based on application requirement. Excessive friction will cause equal amount of performance loss.